

MIPI Monocular Camera Module AN5641 User Manual



Table of Contents

Table of Contents.....	2
Part 1: AN5641 MIPI Camera Module Introduction.....	3
Part 1.1: AN5641 Camera Module Detail Parameter.....	3
Part 1.2: Connector Interface Definition.....	4
Part 2: Supported FPGA Development Board.....	5
Part 3: Hardware Connection and Testing.....	5

Part 1: AN5641 MIPI Camera Module Introduction

The AN5641 camera module adopts the American OmniVision (Howe) CMOS chip image sensor OV5640. Supports DVP and MIPI interfaces. On the AN5641 module, the MIPI interface is connected to the FPGA development board to realize image transmission.



Figure 1-1: AN5641 module product photo

Part 1.1: AN5641 Camera Module Detail Parameter

- Module Interface: 15pin FPC interface with 1.0mm pitch, 2LANE MIPI interface for communication
- support for images sizes: 5 megapixel
- Photosensitive chip: OV5640
- optical size of 1/4"
- Module content: Including OV5640 power supply circuit and clock
- automatic image control functions: Manual focus, automatic exposure control (AEC), automatic white balance (AWB)
- support for output formats: RAW RGB, RGB565/555/444, CCIR656, YUV422/420, YCbCr422, and compression

- Working temperature: -30~70°C, stable working temperature is 0~50°C

Part 1.2: Connector Interface Definition

The AN5641 module is connected to the FPGA development board through a 15Pin 1.0mm pitch FPC flexible cable, and the FPC connector on the module adopts the upper contact method. The interface is defined as follows:

PIN	Signal Name	Description
PIN 1	Ground	Ground
PIN 2	MIPI_LAN0_N	Camera CMOS LANE0 Data Negative Output
PIN 3	MIPI_LAN0_P	Camera CMOS LANE0 Data Positive Output
PIN 4	Ground	Ground
PIN 5	MIPI_LAN1_N	Camera CMOS LANE1 Data Negative Output
PIN 6	MIPI_LAN1_P	Camera CMOS LANE1 Data Positive Output
PIN 7	Ground	Ground
PIN 8	MIPI_CLK_N	Camera CMOS Clock Negative Output
PIN 9	MIPI_CLK_P	Camera CMOS Clock Data Positive Output
PIN 10	Ground	Ground
PIN 11	CAM_PWUP	Camera CMOS Power-on Control Signal
PIN 12	CAM_CLK	Camera CMOS Input Clock Signal
PIN 13	CAM_SCL	Camera CMOS I2C Clock Signal
PIN 14	CAM_SDA	Camera CMOS I2C Data Signal
PIN 15	+3.3V	Power Supply 3.3V

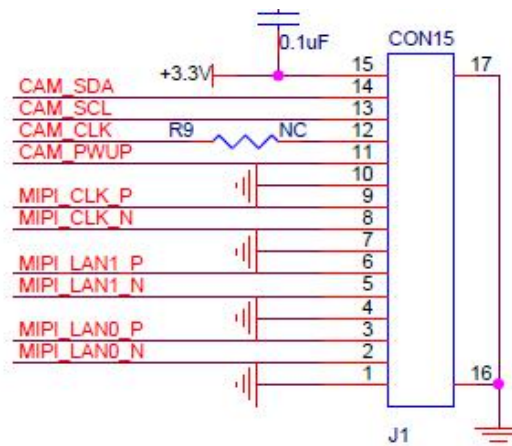

Part 2: Supported FPGA Development Board

Not all ALINX FPGA development boards have reserved MIPI interfaces. Currently, only the following FPGA development boards support MIPI camera capture and display:

Number	FPGA Development Board VPN	MIPI Interface
1	AX7Z020	J23
2	AX7Z035	J10
3	AX7Z100	J10
4	AXU3EG	J23
5	AXU4EV	J23

Part 3: Hardware Connection and Testing

The AN5641 module and the FPGA development board are connected through the FPC flexible flat cable. We have provided a 15PIN heterogeneous flexible flat cable. Because the FPC socket of the module is in upper contact, when inserting the FPC flexible cable, the exposed metal side of the cable needs to be facing up, and fasten it as shown in the figure below:

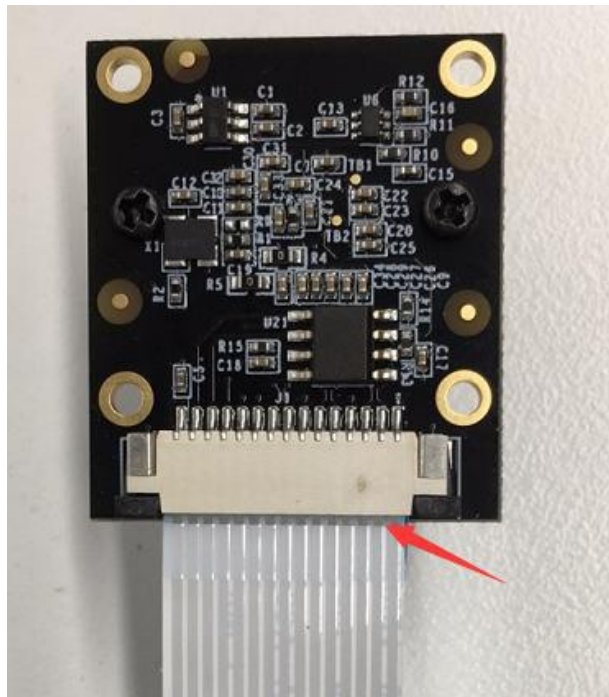

Then connect the other end to the FPGA development board. The picture below shows the connection of the AX7Z020 development board:



The following picture is the picture connected with AX7Z035 or AX7Z100 FPGA development board:

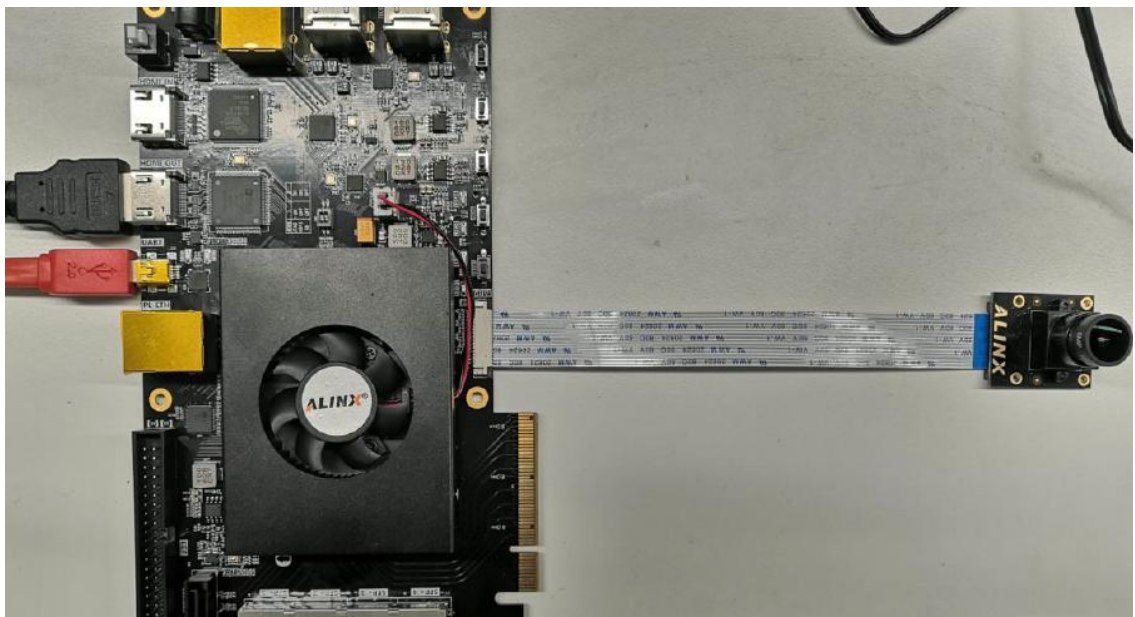

Download the test routines in the VIVADO software development environment to the FPGA development board. We can display the binocular video image to the HDMI display through the HDMI output interface of the FPGA development board. The video display effect is as follows: