

XC7Z1100-2FFG9001

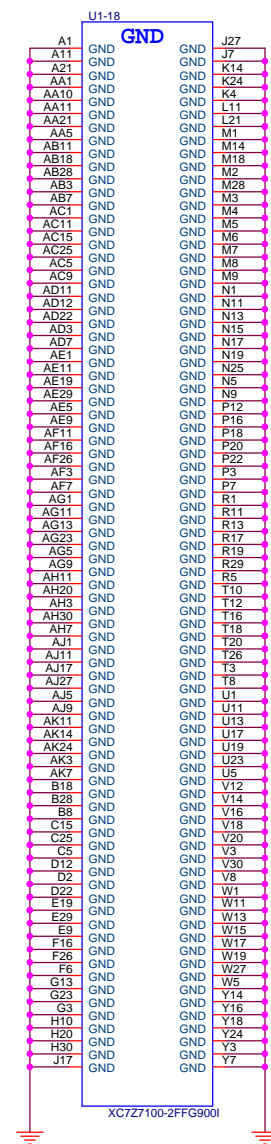

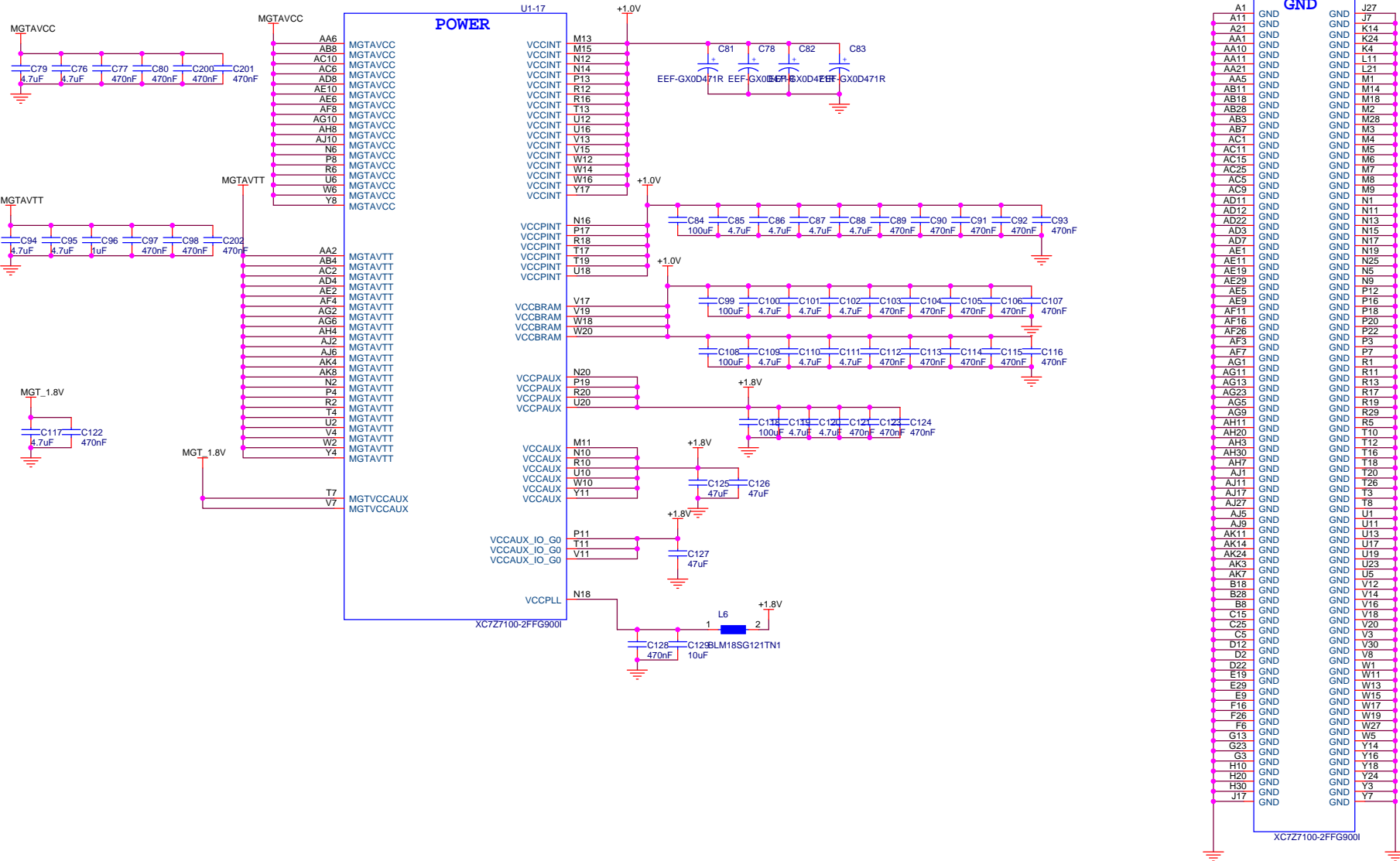

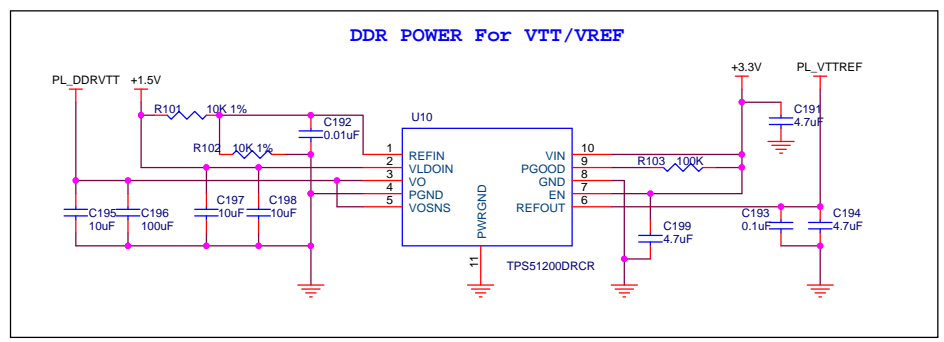
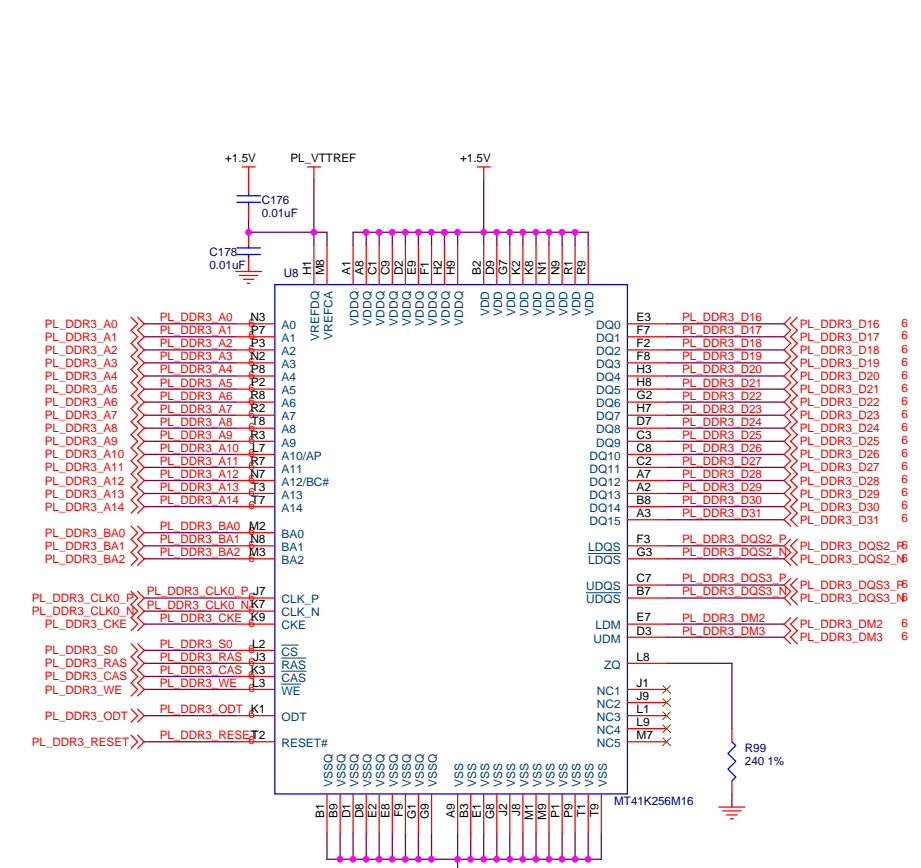
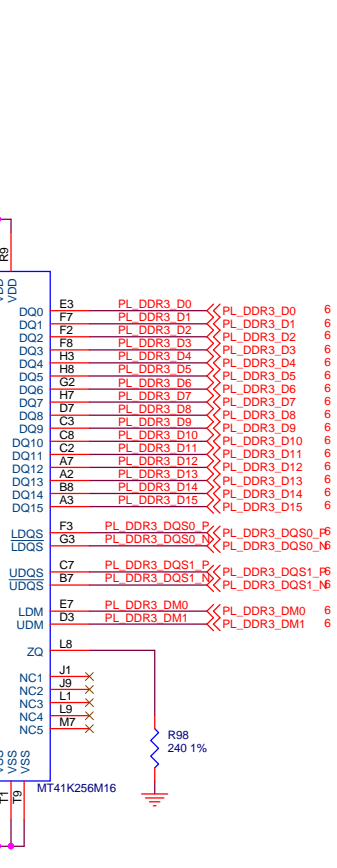
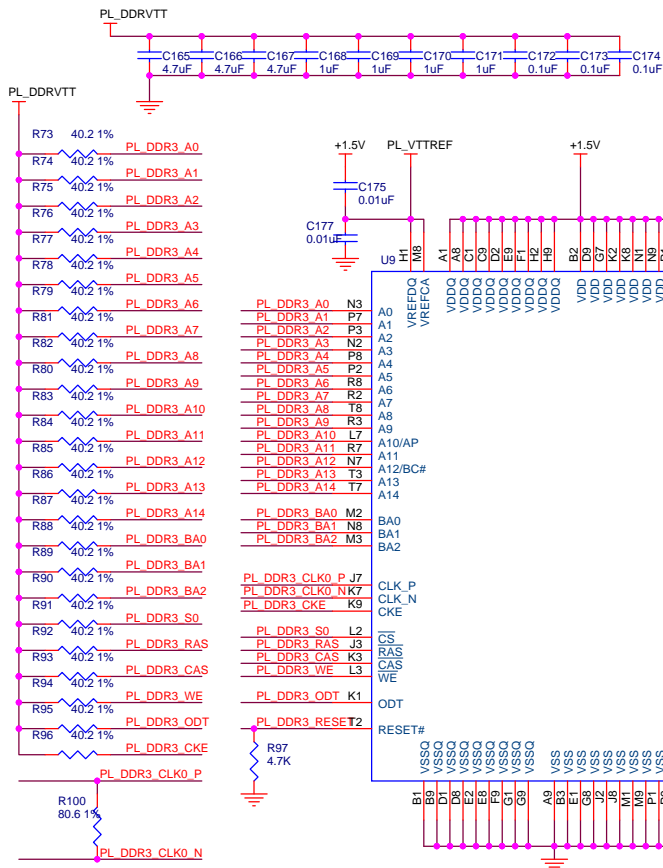
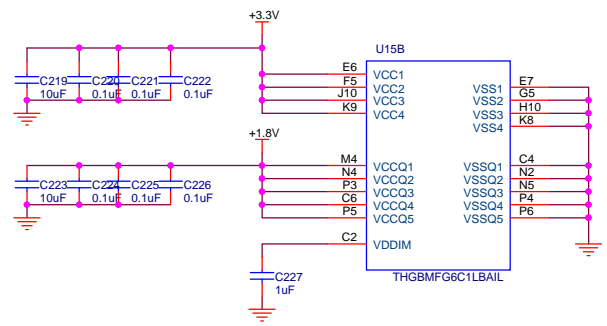
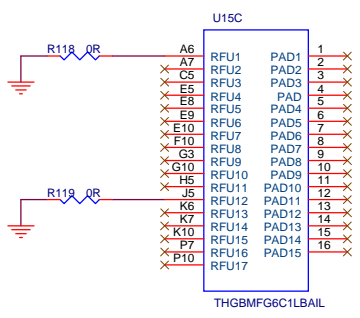
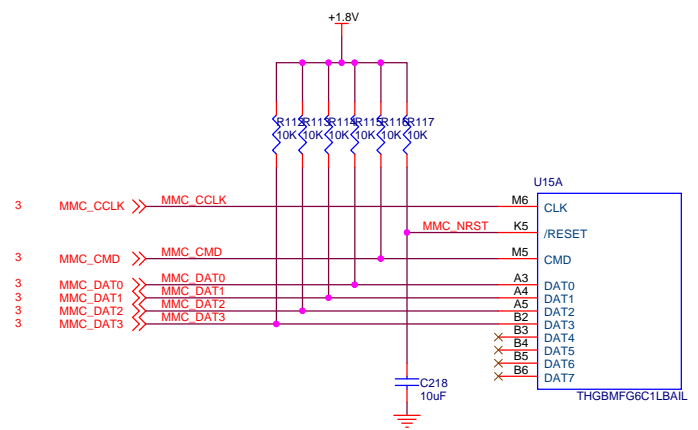
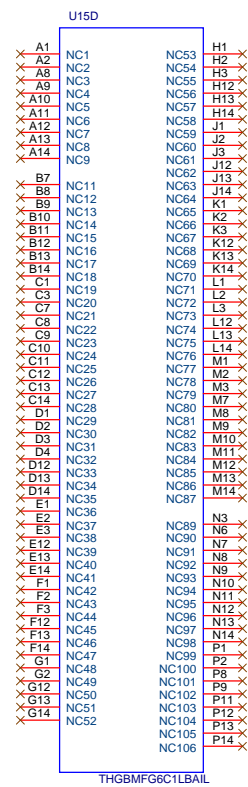
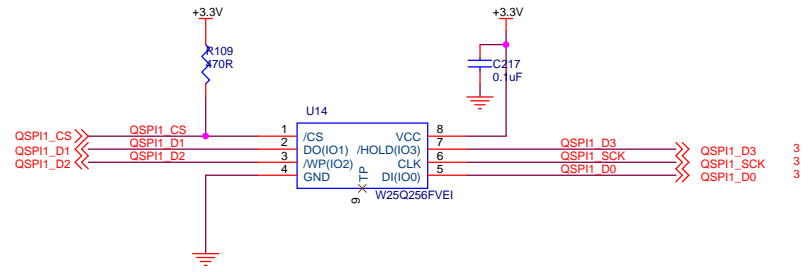
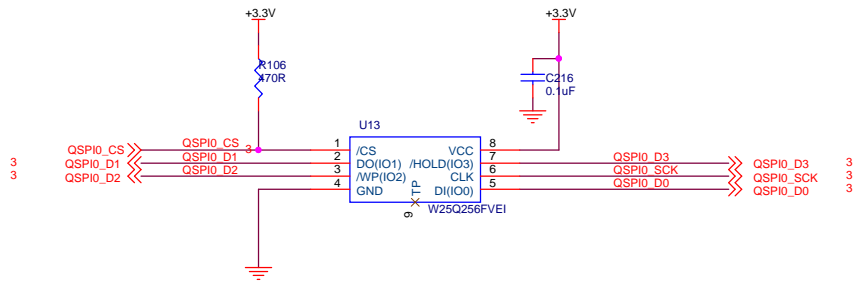

SYSTEM CLOCK

200MHz

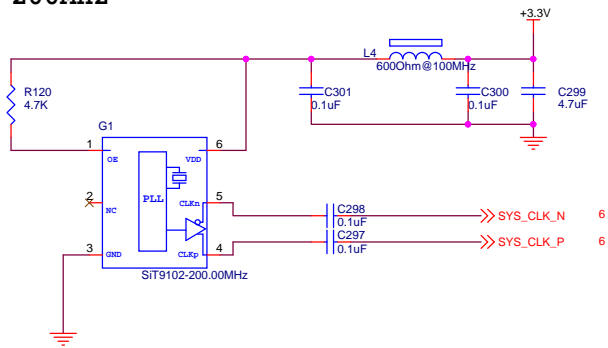

GTX CLOCK

125MHz

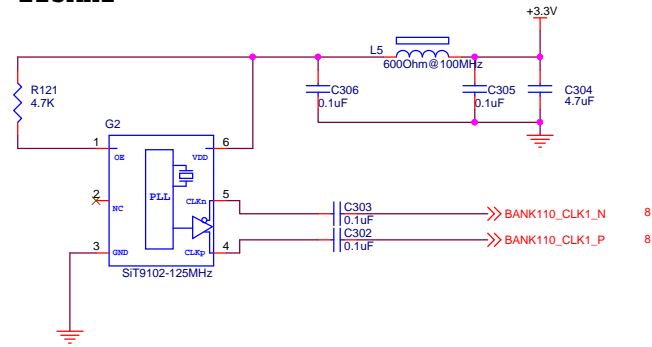

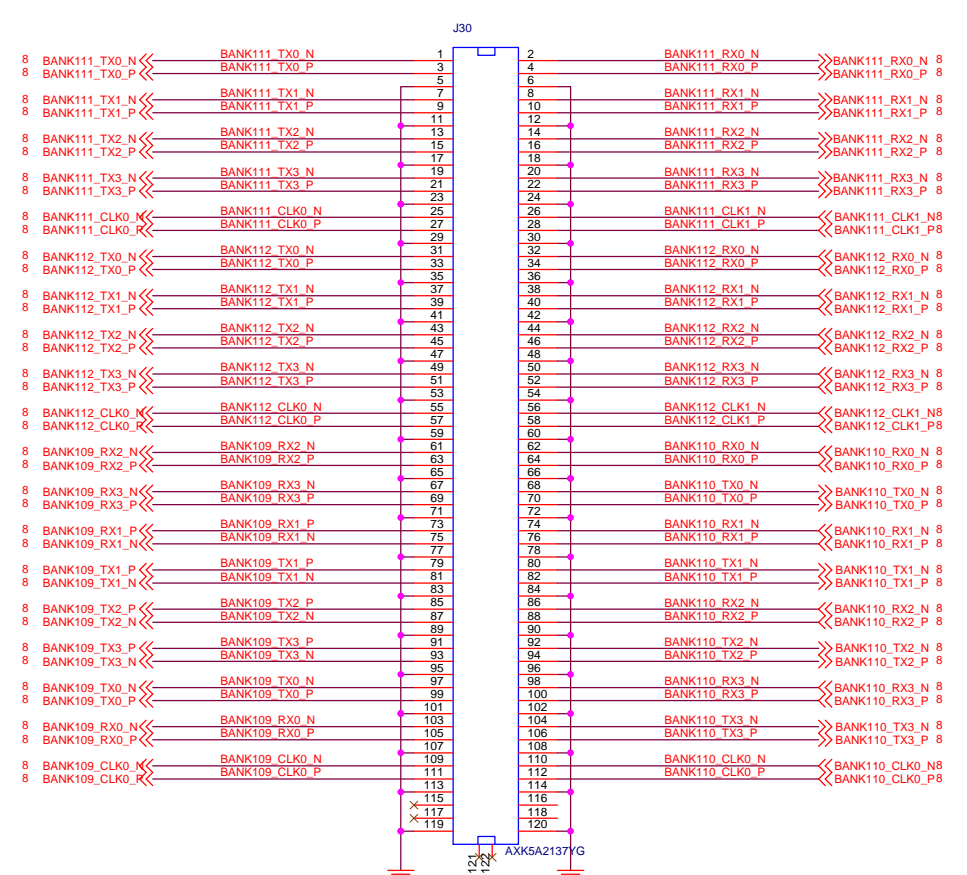
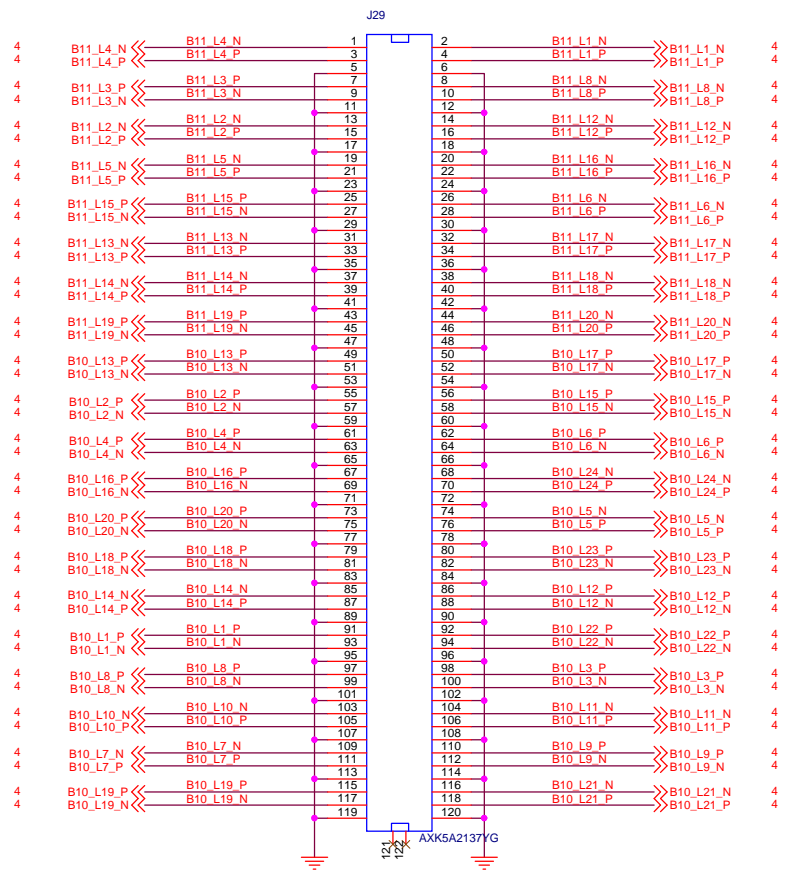

ALINX Confidential

BANK35 IO is 1.8V

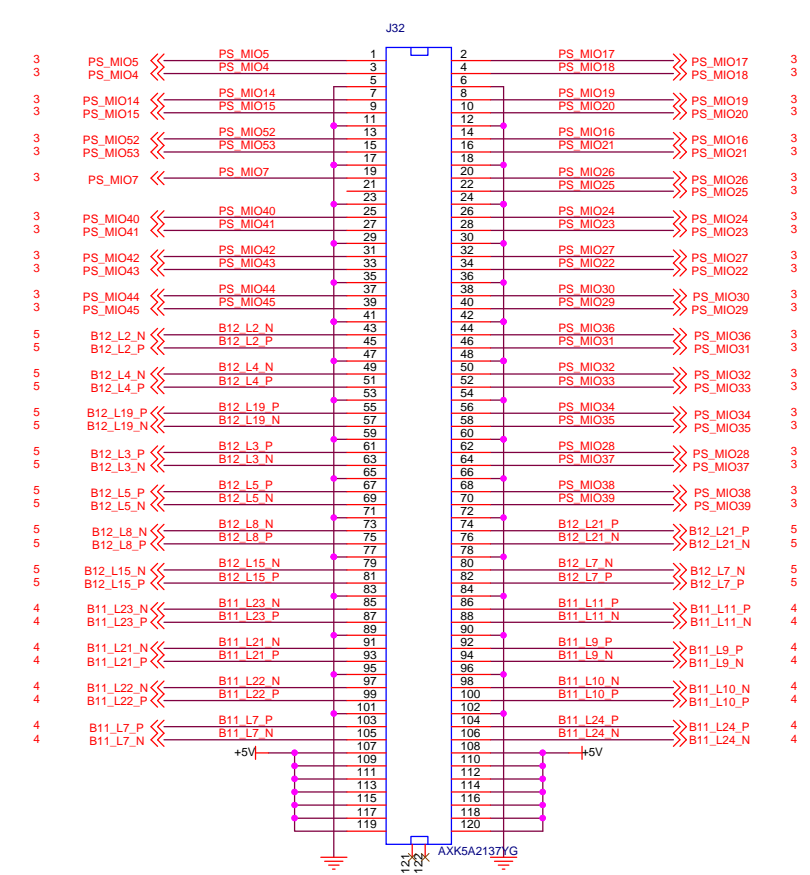
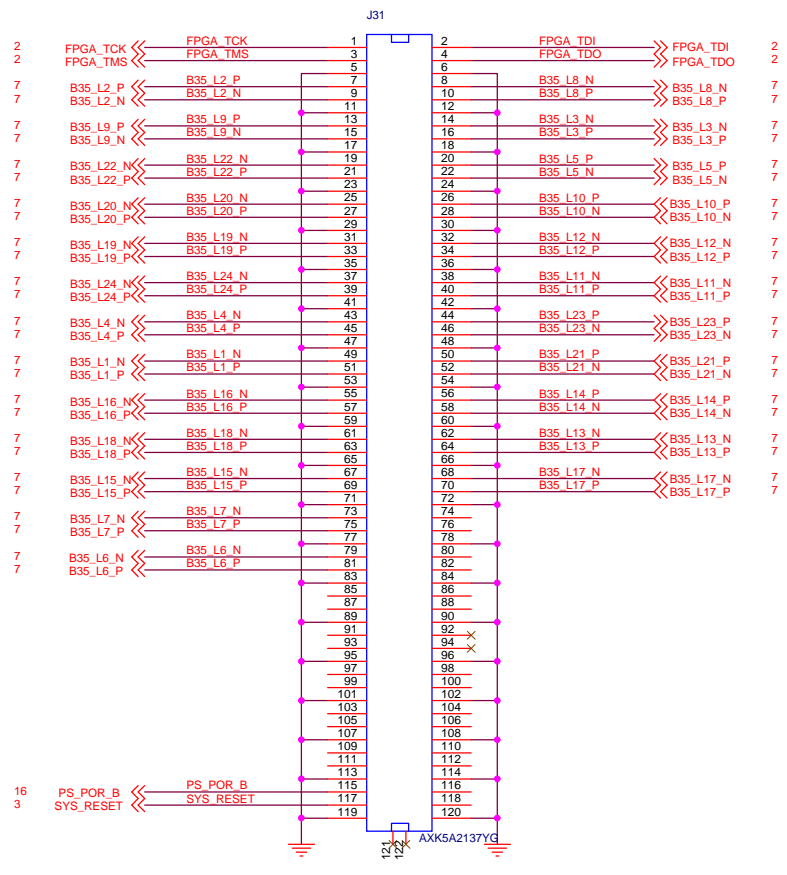

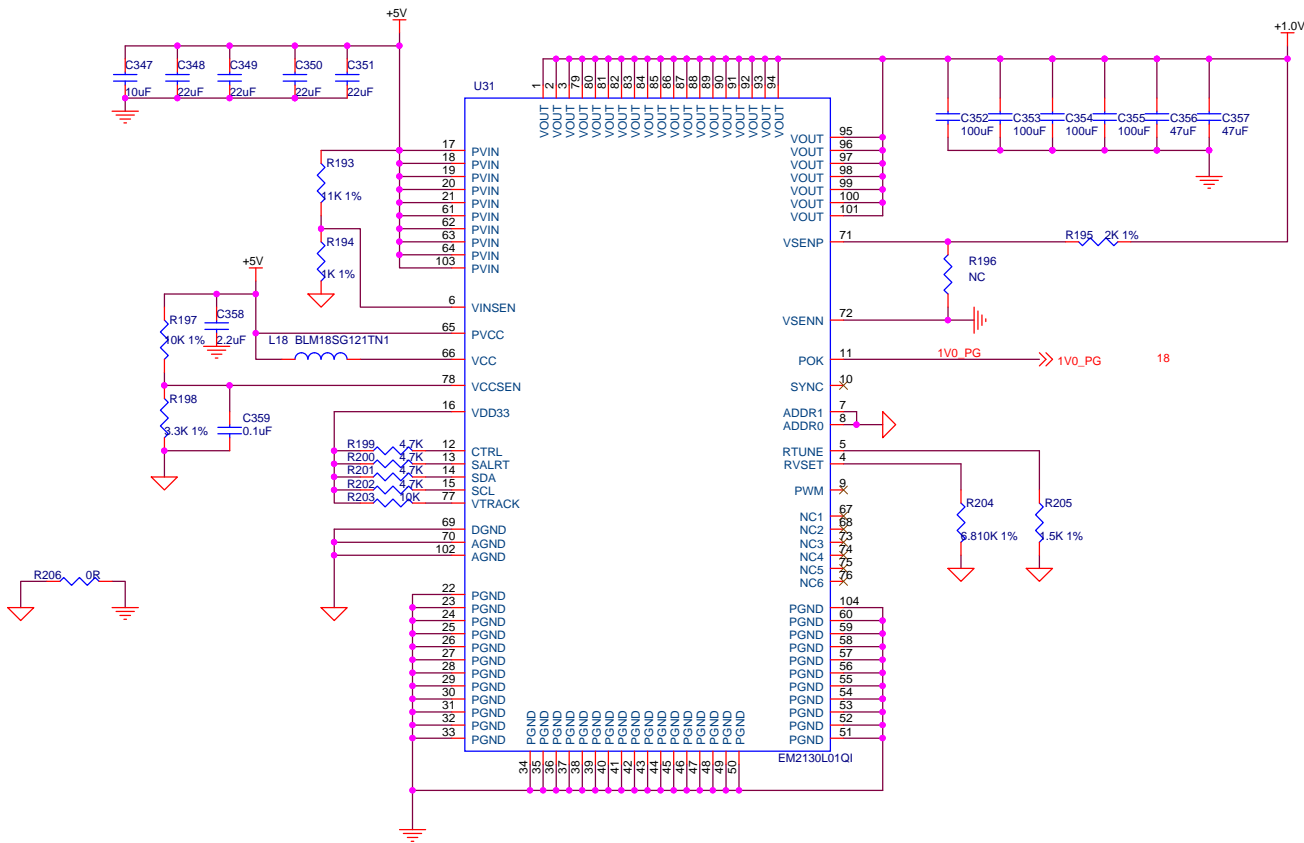

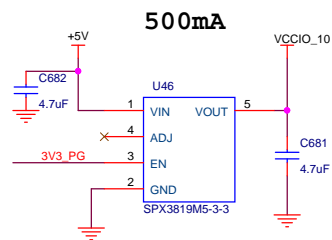
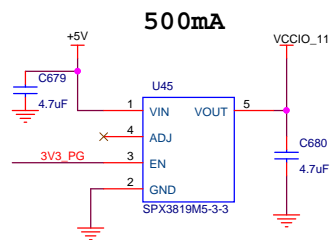
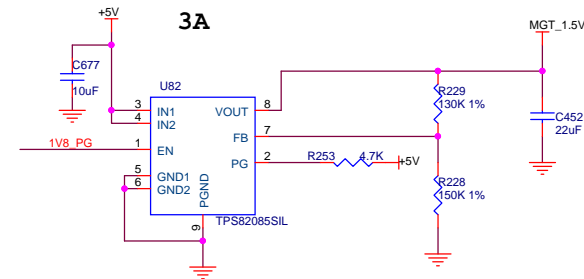
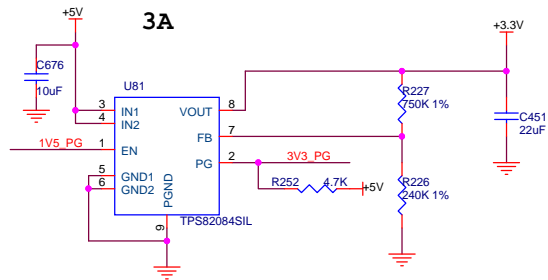
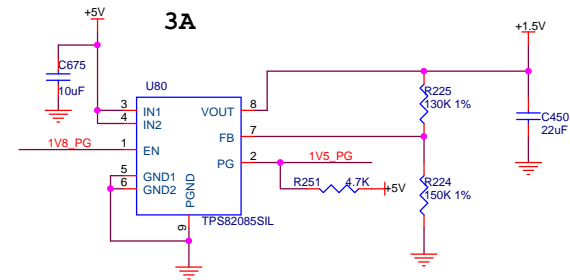
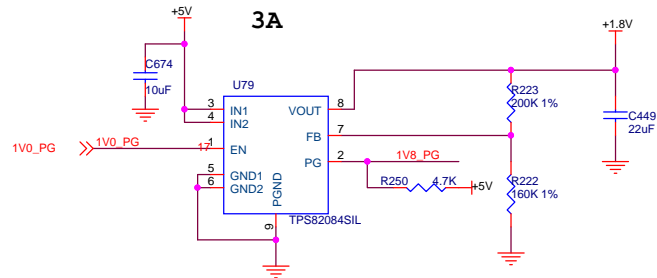

+1.0V 6A

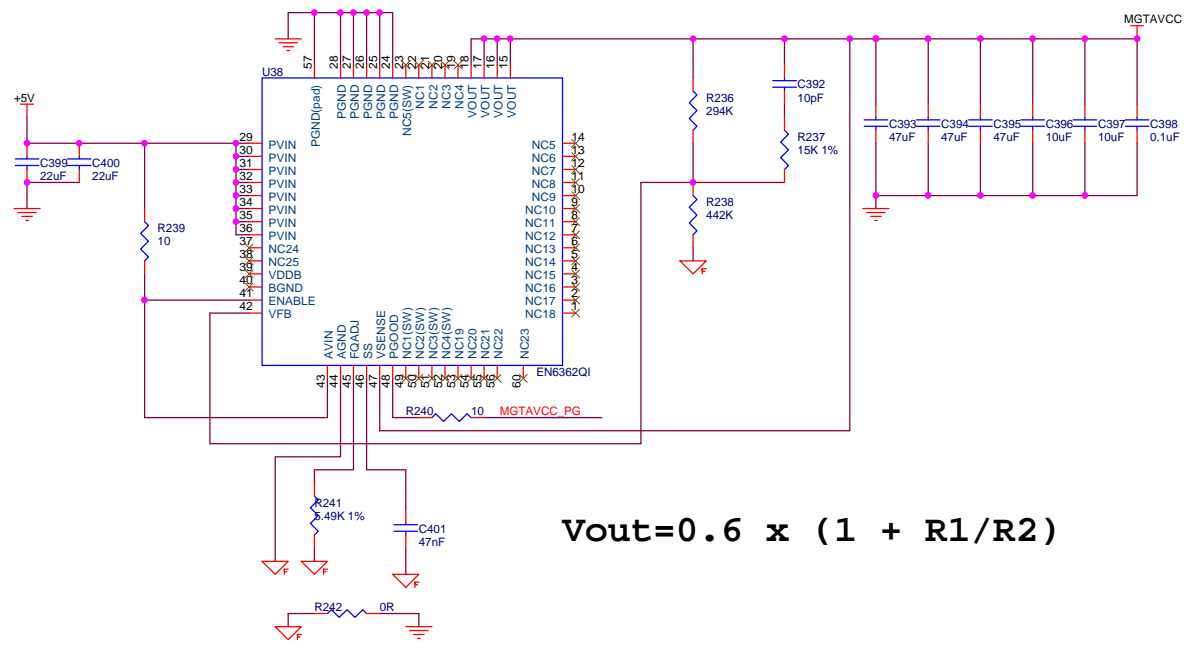

$$V_{out} = 0.6 \times (1 + R1/R2)$$

+1.2V 3A

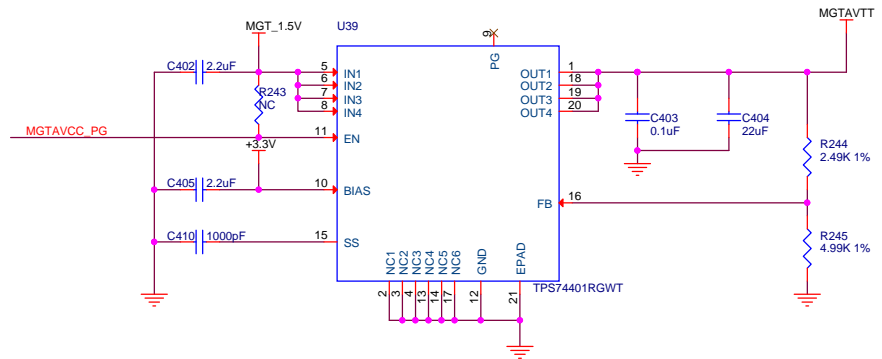

$$V_{out} = 0.8 \times (1 + R1/R2)$$

